



ITT

Electronic Components

Veam VSC Series

19 Pin Connectors for
Lighting Applications

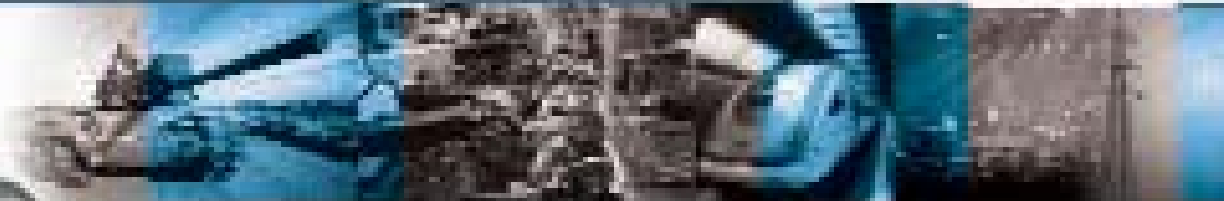

Engineered for life

Distributed By



ITT's Veam VSC is a threaded coupling multi-pin cylindrical connector for lighting applications. Veam is well known for the quality and ruggedness of its popular quarter-turn lock "CIR Series" and has utilized CIR's superior design concepts to provide a very rugged version of the Socapex SL-419 connector family.

Product Features



- Sealed to IP67 when mated
- Socapex compatible
- Machined aluminum shells
- Black, hard anodized (non-conductive) finish for scratch and wear resistant surface
- Heavy duty ribbed coupling ring to provide easy manual coupling and uncoupling
- Six circuit identification on front and rear of inserts
- Recessed area in back of Female insert to accept grounding disk
- Seven forward contacts for "First make, last break" grounding
- Insulating sleeve

Technical Parameters

Voltage Rating: 700 VDC, 500 VAC
 Current Rating: 41A max; 25A Rated
 Temperature Rating: -55° C to +125° C
 Contact Plating: Gold

Mounting Hole Diagram

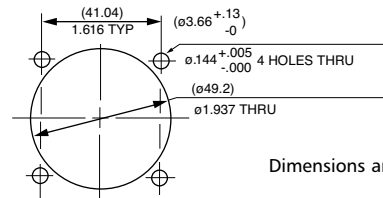

Dimensions are in (mm) inches

Ordering Information

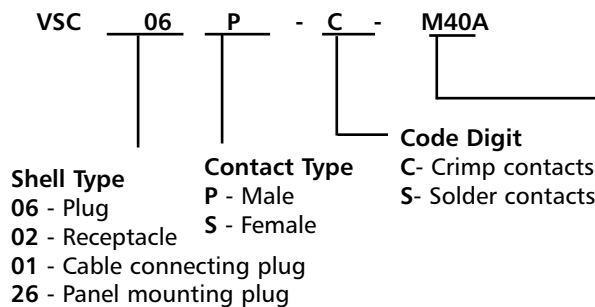

Cable Clamp

M40S	15-23mm
M40A	19-28mm
M40B	22-32mm
PG29	18-26mm
B01	10.3mm diameter European
B02	.450mm diameter SJO USA
	11.8 mm diameter European
B03	.610mm diameter SO USA

Male Connectors



Inline complete with an aluminum backshell and a compression grip cable seal (see cable range above). Both solder or crimp contacts available.

Inline complete with an aluminum backshell and a break out strain relief system (see cable range above). Both solder or crimp contacts available. Watertight to IP67.

Panel Plug (see mounting hole dimensions above). Both solder or crimp contacts available.

Female Connectors



Inline complete with an aluminum backshell and a compression grip cable seal (see cable range page 2). Both solder or crimp contacts available.



Inline complete with an aluminum backshell and a break out strain relief system (see cable range page 2). Both solder or crimp contacts available.



Panel receptacle (see mounting hole dimensions on page 2). Both solder or crimp contacts available.

Contacts



Crimp
Solder



Male (pin) copper alloy, gold plated.
Accommodates wire size 12 to 14 AWG
P/N 49102T58 male crimp
P/N 49150T58 male solder

Female (socket) copper alloy, gold plated.
Accommodates wire sizes 12 to 14 AWG.
P/N 49103T58 female crimp
P/N 49151T58 female solder

Panel Gasket



Neoprene .063" thickness, for use with male or female panel mount.
P/N 98901

Ground Disc



Ground disc is a perforated press-on metal disc used to buss together the ground ring of contacts used in a 6 circuit cable system.

P/N 99197-6-10T12

Assembly Tools



1. Crimp tool frame A manual ratchet action crimper with 4-point indent. Guarantees repeatable gas-tight crimp connections. Specify P/N AF8
2. Contact positioner A turret used to position the contacts for proper crimp location. Specify P/N A98906VSC
3. Insertion tool Used to install contacts from the rear of the insert. Specify P/N 46736
4. Extraction tool kit Consists of a handle with two tips and is used to push out both male and female contacts from the front of the connector. Specify P/N A43240VSC
5. Hex wrench Used to attach the turret to the crimp tool frame. Specify P/N M2700-420

Pneumatic crimp tools also available.



ITT



**Veam Customer Support
Locations**

AMERICAS

100 New Wood Road
Watertown, CT 06795
phone: 1.860.274.9681
fax: 1.860.274.4963

EUROPE

Germany

Postfach 1120, Cannonstrasse1
Weinstadt, 71365
phone: 49.7151.699.0
fax: 49.7151.699.217

Italy

Corso Europa 41/43
Lainate (MI),
Italy 20020
phone: 39.02938721
fax: 39.0293872300

UK

Jays Close, Viabes Estate
Basingstoke, RG22 4BA
phone: 44.1256.311200
fax: 44.1256.323356

Distributed By:
Creative Stage Lighting
North Creek, NY

P • (518) 251-3302
<http://www.creativestagelighting.com>